

Structural Nonlinear Analysis of a Disconnecter Pelikelo (a kind of hook) using ANSYS/Workbench

Mário Coutinho

MCS Engineering LTDA.

Fátima Souza, M.Sc., Gabriel Silva e Decio Paiva

SOFTEC Software Technology

Rio de Janeiro, Brazil

Abstract

The objective of this work is to analyze the structural integrity of a device used to launch torpedo-stakes (structural support to fix platforms in the ocean ground) in the sea. This device named Pelikelo make a connection between the fixed chain and the chain attached to the stake. The use of this device helps PETROBRAS to reduce costs during the installation of the stakes and contribute to reduce the trash in the ground of the ocean, considering that part of the chain is recuperated during this operation. Pelikelo is a new piece developed and patented by MCS to be used inside the ocean to launch the stake. The first operational test of this piece was verified by Classification Societies. This device is a kind of hook composed of three parts. The intermediate piece named Pelikelo open during the operation to release the chain connected to the stake which will be fixed in the ocean ground to support offshore platforms. The solid model was elaborated in a CAD program as an assembly composed of 10 parts, including 5 bolts, 2 shackles and the 3 main parts including the Pelikelo. The finite element model is composed of high order solid elements. The mesh was elaborated using the hexadominant meshing technique. The contacts between parts are surface-to-surface with friction. A nonlinear static stress analysis, in ANSYS/Workbench, is executed using a nonlinear isotropic hardening material model. The load is multiplied by a dynamic factor according to the technical codes. Several analyses were executed to adjust mesh, parameters, algorithms, types of contacts elements and to choose the best solver for this analysis. Several analyses were executed with different distribution of loads. Plastic strains appeared in some regions, mainly in the internal surface of the Pelikelo. Based in these results the geometry of Pelikelo will be modified to avoid plasticity and to respect the safe factor requested by the technical codes and Classification Societies. Although the virtual prototype and the analysis executed in ANSYS are simple, the simulation analysis was very important in this project. It was required by the client due to the difficulties when trying to simulate the operational conditions of working in the ocean in laboratory tests.

Introduction

Due the increasing of the oil exploration in Brazil, PETROBRAS is constructing a great amount of offshore platforms in the last years, mainly in the region of the Campos Basin, State of Rio de Janeiro. The great number of platforms concentrated in that region is causing many operational problems. The proximity of these platforms to each other and the lack of space around causes much interference among equipments connected to the platforms such as pipes, manifolds, cables, supports to fix platform and other equipments that are used in the process of perforation, extraction and distribution of oil. Besides, accessories used to carry or launch equipments in the sea are lost and a great amount of trash is being deposited in the ocean ground, causing a great pollution in the sea.

The conventional methods used to launch torpedo-stakes and manifolds in the ocean are expensive because a large amount of chains is lost in this process. Companies which work in the oil and gas industry are looking for solutions to minimize these problems, decreasing the interference among equipments and the trash in the ocean.

One of the solutions implemented in the process of launching manifolds and torpedo-stakes was the piece Pelikelo developed and patented by MCS Engineering. The great advantages of this device are:

- 1) It can be reused in many launcher processes;
- 2) It contributes to reduce the amount of chains lost after the launcher of the equipments in the sea;

- 3) It permits recuperate part of the chains, saving money to the companies;
- 4) It is an ecological device that contributes to keep the ocean ground cleaner, without chains.

Procedure

The assembly of pieces analyzed here is composed of three parts:

- 1) A superior piece connected in the top to a chain fixed in a boat and connected in the bottom to the Pelikelo;
- 2) The main piece named Pelikelo which has a small piece that keep the mobile arm closed;
- 3) An inferior piece connected in the top to the Pelikelo and in the bottom to the chain that sustain the equipment which will be launched.

The process of launching the equipment in the ocean has the following steps:

- 1) A chain connected to the superior piece of the assembly is fixed in a support inside a boat;
- 2) The chain is moved until the assembly stay in a certain depth inside the ocean;
- 3) A robot inside the ocean takes out the piece that held the arm of the Pelikelo, which open and release the inferior piece with the chain and the equipment;
- 4) The chain fixed to the boat and the superior piece of the assembly and the Pelikelo are recuperated to be used in the next operation.

Finite Element Model:

The solid model of the first type of the Pelikelo is composed of three parts created in a CAD program and imported to ANSYS Workbench. The mesh was elaborated using the hexadominant module. Different sizes of elements were defined and the function of mapped face was used to control the mesh and obtain more hexahedral elements as shown in Figures 1 and 2.

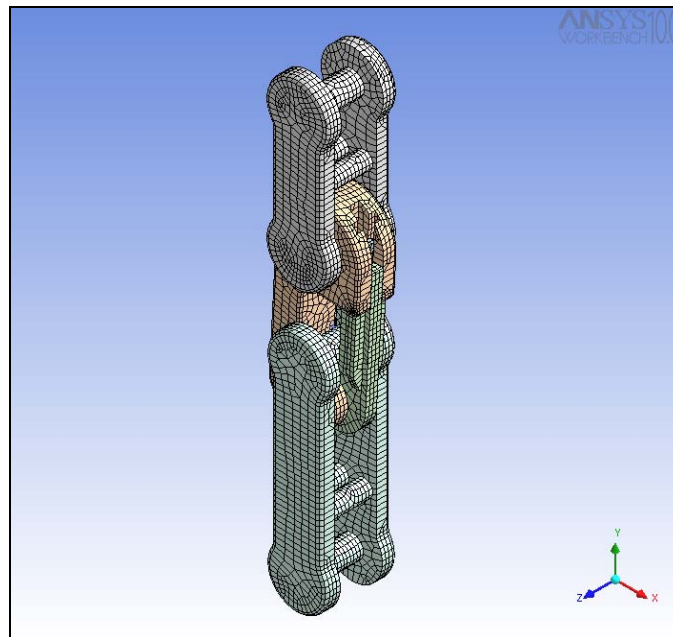

Figure 1. Finite Element Model – Assembly of Pelikelo

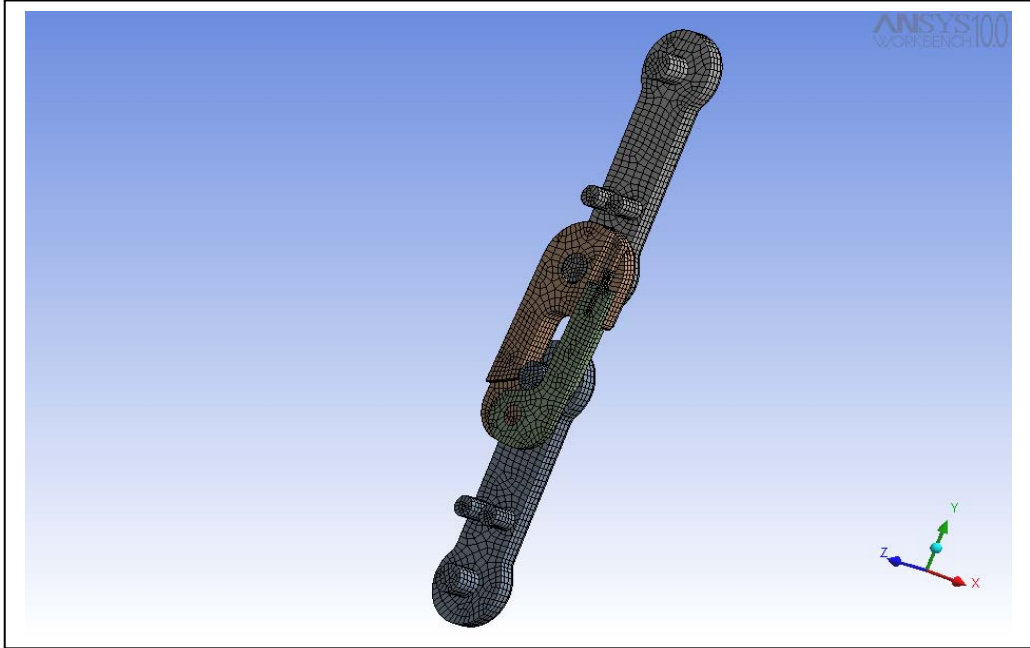

Figure 2. Finite Element Model – Section of the Assembly of Pelikelo

A second type of the assembly analyzed is composed for the main piece Pelikelo connected directly with a chain that contact the arm of the Pelikelo, as shown in the Figure 3. It is shown also the half of the small piece that locks the arm in the structure of the Pelikelo before the operation executed to release equipment.

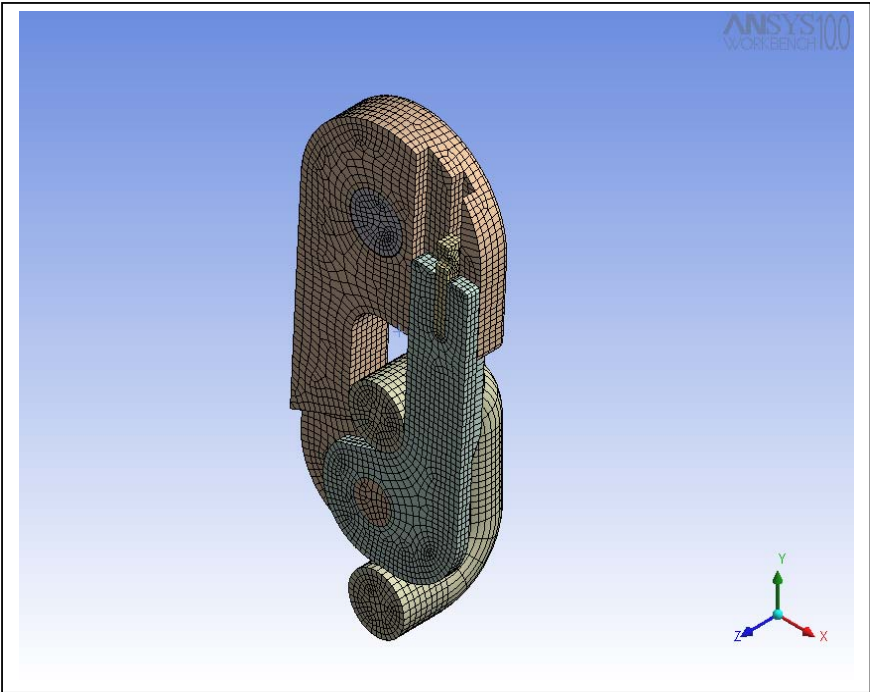

Figure 3. Finite Element Model – Section of the Pelikelo connected to a chain

Contacts Elements:

Between the Pelikelo and the connections with the superior and with inferior parts, there are surface-to-surface contacts elements with friction. These contacts were automatically identified in the Design Simulation Module. Around the piece used to keep the arm of the Pelikelo closed, the program identified one contact between this piece and the Pelikelo. After trying to run the analysis, it was identified the need of separate the contact by face. The single contact was deleted and pairs of contacts between the piece and the Pelikelo were created in the following locations: each frontal face, each lateral face and in the bottom face. This piece is very important during the operation. It can move during the operation, but it can not deform. If this piece deform during the operation, the robot can have difficulties or not be able to take it out and the Pelikelo does not open to release the equipment. So, all contacts must be model in the best way to transmit the correct loads from the Pelikelo to this piece.

Boundary Conditions:

They are applied in the surface of the top connection of the superior piece with the chain. Rotation is released around the Z axes, the lateral, vertical movements and rotations around X and Y axes are restricted.

Loads:

A pressure load is applied in the surface of the bottom connection of the inferior piece, in a region which corresponds to the contact area between the piece and the chain that sustain the equipment.

Analysis

The first structural analysis executed was static nonlinear, considering the linear material and contacts surface-to-surface with friction. As in many regions of the pieces of the assembly of the Pelikelo appeared stresses higher than the Yield Stress of the material, it was necessary to include the curve of the material, Stress x Strain, as shown in the Figure 4, to represent the yield of the material and the plastic strains.

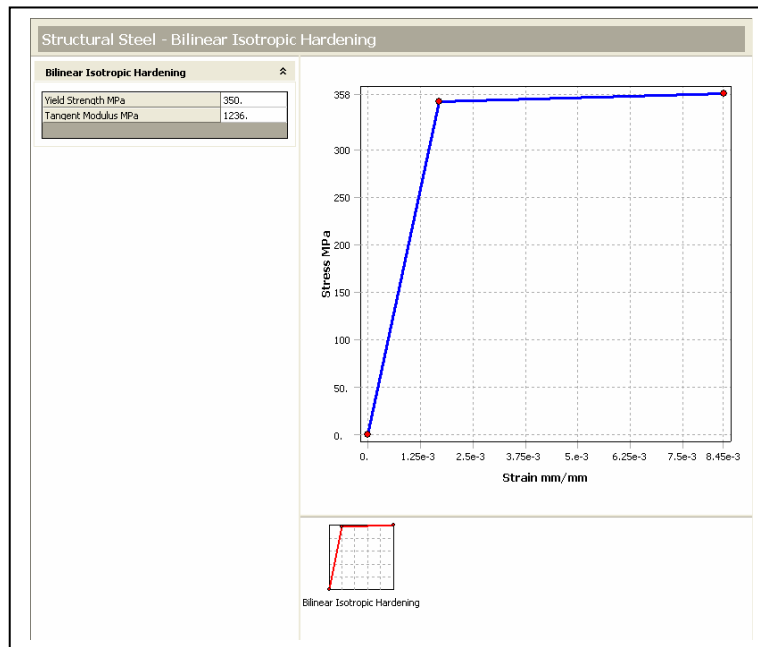

Figure 4. Curve of the Material – Stresses x Strains

The material model used in these analyses is the bilinear isotropic hardening.

Three different geometries of the Pelikelo respectively with loads of 150 Ton, 250 Ton and 600 Ton were analyzed.

The main challenges of these analyses were the choice of the solver and the adjustment of analysis and contact parameters to avoid rigid body movement and get the convergence with a good precision. This assembly of pieces behaves almost as a mechanism. For some values of contact stiffness, the structure has a rigid body movement. Also, the contact algorithm has a great influence in the convergence of the analysis.

As the correct analysis must include the non-linearity of the material, the load increments must be very small to keep the allowable plasticity rate, in the moment of the analysis in which the material begins to yield.

It is very important also to have very refined and similar meshes in the regions of contacts because contacts are flexible in the both side and it happens sliding between them during the analysis.

Different meshes, parameters contact, solvers and load increments were tested in several analyses to improve the convergence and to verify the precision of the results.

Analysis Results & Discussion

The device Pelikelo and the pieces connected to it were designed using some basic material strength formulations, considering the linear behavior of these pieces, because there is no Technical Code to be used in these calculations.

Some simple laboratory tests were made, but they were not able to represent the complete behavior of the assembly of the Pelikelo.

So, the computational simulation analysis was required to check the results obtained in the hand calculations and to complement the results obtained in the laboratory tests.

Besides, it was necessary to verify the correct transference of loads from the pieces used to support the equipments through the contacts to the Pelikelo, mainly in the small piece used to lock the arm of the Pelikelo. This piece is the most important part of the assembly because it is responsible for the opening of the arm which releases the equipment to be launched in the ocean. So, this piece and the region of the Pelikelo around it can not be deformed, otherwise the piece will not be able to be taken out by the robot and the arm will not open.

The nonlinear analyses were very important to show the yield of the material and plastic strains, around 2%, that happen in some points of the small piece used to lock the arm in the fixed structure of the Pelikelo.

Also, in all assemblies, with different geometries, it was verified that there was yield of the material in the internal part of the Pelikelo, with plastic strains between 2% and 5%, due the efforts and motion between the pieces of the assembly of the Pelikelo that cause a bending in this region.

It was verified also that in the internal part of the arm, in the internal region occupied by the small piece that lock the arm in the fixed structure of the Pelikelo, there was yield in some points and plastic strain around 2% and 4% for all different geometries analyzed.

Due these high stresses and strains, which appear in many regions of the structure of the Pelikelo, the design of the Pelikelo will be change and perhaps a material with a higher Yield will be used.

In Figures 5 to 7 are shown the distribution of Von Mises stress in Pelikelos that support 150, 250 and 600 Tons. The higher stresses are localized in the internal surfaces of the fixed parts, caused by the bending of this region. The geometry of these regions must be changed to avoid the bending. Also, a material with a higher Yield Stress can be used.

In the Figure 8 is shown the distribution of Von Mises Stresses in the small piece used to lock the arm of the Pelikelo. As this piece can not deform, the material must have a higher Yield Stress or its thickness must be increased.

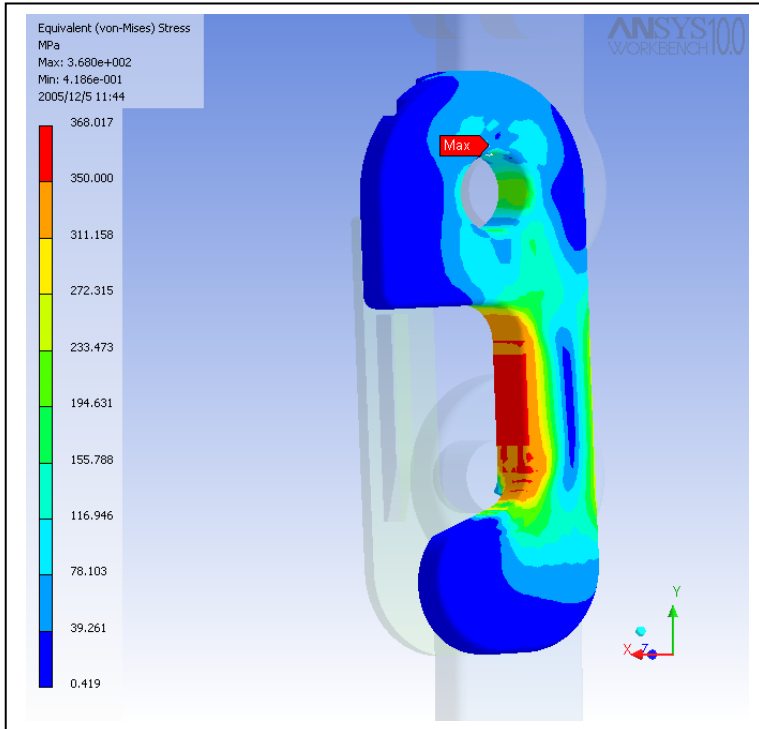

Figure 5. Von Mises Stresses for the Pelikelo with a load of 150 Ton

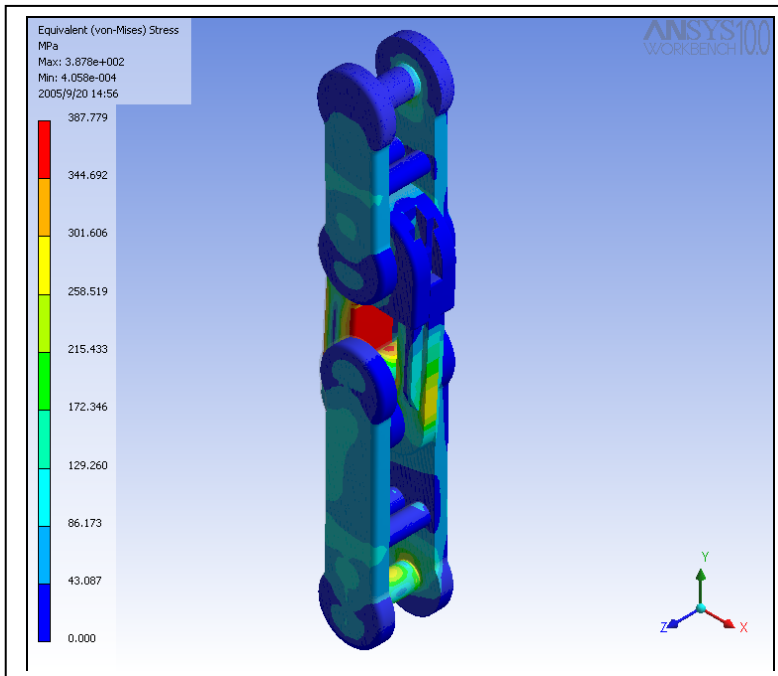

Figure 6. Von Mises Stresses for the Pelikelo with a load of 250 Ton

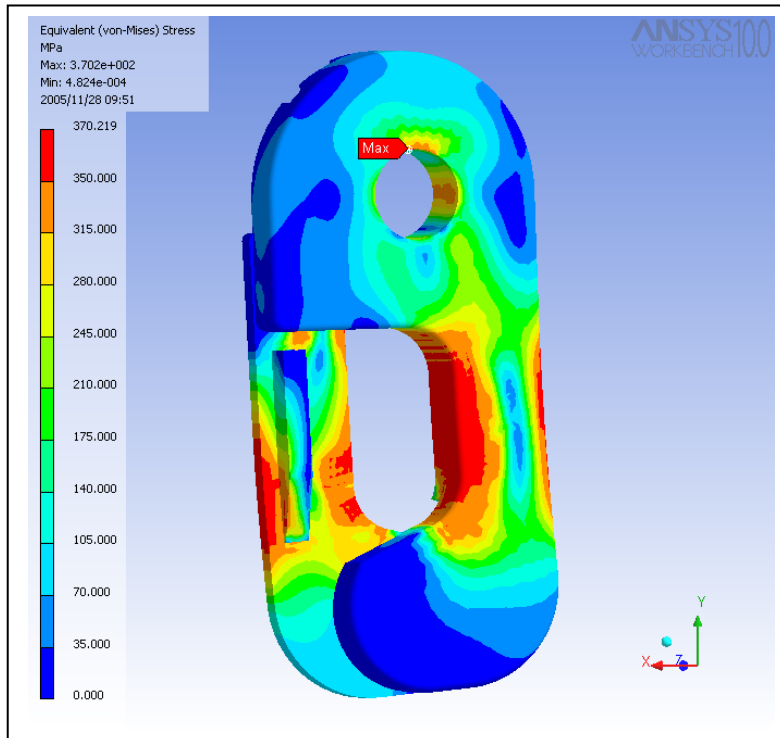

Figure 7. Von Mises Stresses for the Pelikelo with a load of 600 Ton

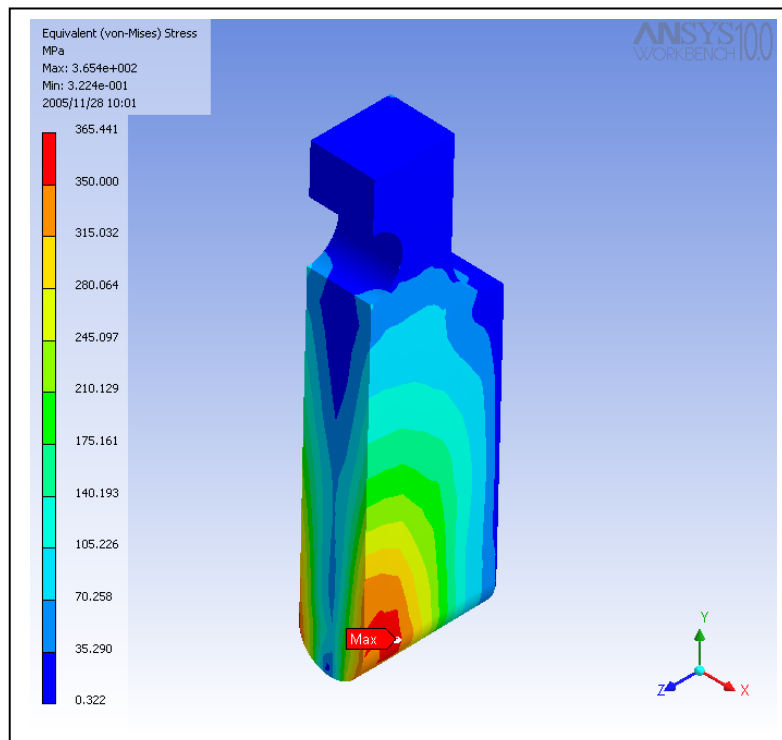

Figure 8. Von Mises Stresses in the Piece that lock the arm to the fixed part of the Pelikelo – Effect of the Load of 600 Ton

Conclusion

These pieces were designed through hand calculations because there is no Technical Code to check them.

Test in laboratory to simulate operational conditions and the behavior of the Pelikelo, supporting loads around 600 Ton, are complex and expensive.

So, the computational simulation analysis was relevant to represent and understand the behavior of the Pelikelo and to analyze the structural integrity of this assembly, mainly of a small piece used to lock the arm in the fixed part of the Pelikelo, which can not be damaged during the operation.

Three different geometries were analyzed respectively with loads of 150 ton, 250 Ton and 600 Ton.

Static analyses were executed considering the nonlinearities of contact and the nonlinear behavior of the material. Loads were applied with a dynamic factor recommended by Codes used in the engineering industry to consider the dynamics effects of the analyses.

In ANSYS Workbench, Design Simulation was used to import the model, identify automatically the contacts, define contact parameters, solvers and monitor analyses. Hexadominat Module was used to elaborate the mesh.

The analyses in Workbench had a very good performance. The change in the mesh was very efficient and the redefinition of contact parameters was very fast.

The results obtained in these analyses were very important to understand the behavior of the assembly of the Pelikelo and to help the designer to improve its project to have a more strength piece.

References

- 1) ANSYS Manuals, Version 10.0, ANSYS, Inc.